

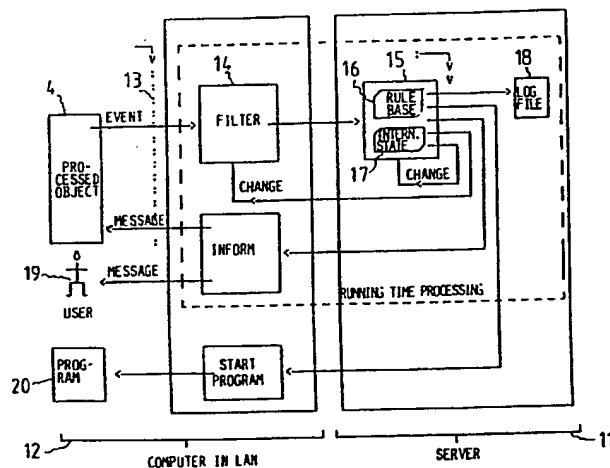

## INTERNATIONAL APPLICATION PUBLISHED UNDER THE PATENT COOPERATION TREATY (PCT)

(51) International Patent Classification <sup>5</sup> :  G06F 11/34	A1	(11) International Publication Number: <b>WO 93/00632</b>  (43) International Publication Date: 7 January 1993 (07.01.93)
<p>(21) International Application Number: PCT/SE92/00456</p> <p>(22) International Filing Date: 22 June 1992 (22.06.92)</p> <p>(30) Priority data: 9101942-2 20 June 1991 (20.06.91) SE</p> <p>(71) Applicant (for all designated States except US): ICL DATA AB [SE/SE]; Box 40, S-164 93 Kista (SE).</p> <p>(72) Inventor; and (75) Inventor/Applicant (for US only) : SKAGERLING, Lennart [SE/SE]; Soldatvägen 45A, S-191 73 Sollentuna (SE).</p> <p>(74) Agent: AWAPATENT AB; Box 5117, S-200 71 Malmö (SE).</p>	<p>(81) Designated States: AU, CA, FI, JP, NO, US, European patent (AT, BE, CH, DE, DK, ES, FR, GB, GR, IT, LU, MC, NL, SE).</p> <p>Published With international search report. In English translation (filed in Swedish).</p>	

(54) Title: METHOD AND SYSTEM FOR MONITORING A COMPUTER SYSTEM



## (57) Abstract

In a method and a system for monitoring and changing the operation of a computer system, the system comprises a local area network or interconnected local area networks, each having a plurality of computers. The system further comprises at least one event report generator in each executable program (4) whose execution should be monitored; an event processing machine (15) for processing events which are reported by an event report generator depending on a flexible rule base (16) which is included in the event processing machine and associates a certain event with a predetermined action, for determining the action associated with the reported event; equipment (18) controlled by the event processing machine and adapted to perform an action determined by the event processing machine; and an interface (13) for transferring an event reported by an event report generator to an event processing machine, and for transmitting a message regarding an action associated with the event, from the event processing machine to a program which is executable in the computer system, for changing or starting thereof.

*FOR THE PURPOSES OF INFORMATION ONLY*

Codes used to identify States party to the PCT on the front pages of pamphlets publishing international applications under the PCT.

AT	Austria	FI	Finland	MI	Mali
AU	Australia	FR	France	MN	Mongolia
BB	Barbados	GA	Gabon	MR	Mauritania
BE	Belgium	GB	United Kingdom	MW	Malawi
BF	Burkina Faso	GN	Guinea	NL	Netherlands
BG	Bulgaria	GR	Greece	NO	Norway
BJ	Benin	HU	Hungary	PL	Poland
BR	Brazil	IE	Ireland	RO	Romania
CA	Canada	IT	Italy	RU	Russian Federation
CF	Central African Republic	JP	Japan	SD	Sudan
CG	Congo	KP	Democratic People's Republic of Korea	SE	Sweden
CH	Switzerland	KR	Republic of Korea	SN	Senegal
CI	Côte d'Ivoire	LI	Liechtenstein	SU	Soviet Union
CM	Cameroon	LK	Sri Lanka	TD	Chad
CS	Czechoslovakia	LU	Luxembourg	TC	Togo
DE	Germany	MC	Monaco	US	United States of America
DK	Denmark	MG	Madagascar		
ES	Spain				

METHOD AND SYSTEM FOR MONITORING A COMPUTER SYSTEM

The invention relates to a method and a system for  
5 monitoring and changing the operation of a computer system  
which comprises a plurality of computers in a local area  
network or a plurality of interconnected local area net-  
works, each having a plurality of computers.

Equipment and programs which are intended for moni-  
10 toring the operation of a computer or the execution of a  
program are previously known. However, they are specific  
for the computer concerned or the program concerned.

The object of the present invention is to provide a  
common instrument, i.e. a general method and a general  
15 system for such monitoring and changing of a computer  
system having a plurality of computers interconnected in  
at least one local area network. Such monitoring and  
changing may concern e.g. error processing, i.e. detect-  
ing, registering and rectifying errors occurring during  
20 the operation of a computer system; performance proces-  
sing, i.e. detecting, registering and changing the per-  
formance of a computer system in operation; and utilis-  
ation processing, i.e. detecting, registering and changing  
the utilisation of different resources of the computer  
25 system, which are utilised by different users and  
programs.

In a system for monitoring and changing the operation  
of a computer system of the type mentioned by way of intro-  
duction, the object of the invention is achieved by the  
30 system comprising at least one event report generator in  
each program which is executable in the computer system and  
whose execution should be monitored; an event processing  
machine for processing events which are reported by an  
event report generator in a monitored program during the  
35 execution thereof, depending on a flexible rule base which  
is included in the event processing machine and associates  
a certain event with a predetermined action, for deter-

mining the action associated with the reported event;  
equipment controlled by the event processing machine and  
adapted to perform an action determined by the event pro-  
cessing machine; and an interface for transferring informa-  
5 tion about an event reported by an event report generator  
in a monitored program, to an event processing machine, and  
for transmitting a message regarding an action associated  
with the event, from the event processing machine, op-  
tionally via and for processing in a further event proces-  
10 sing machine, to a program executable in said computer  
system and intended for changing or starting thereof.

Suitably, a filter is directly connected to the inter-  
face and adapted to restrict the number of the events re-  
ported which are forwarded to the event processing machine.

15 Moreover, the event processing machine suitably com-  
prises an internal state device, said rule base being  
adapted to associate a certain event with a predetermined  
action which depends on the instantaneous state of the  
internal state device.

20 The equipment controlled by the event processing  
machine may also comprise means for registration of a  
reported event and/or for forwarding a reported event,  
optionally via and for processing in a further event  
processing machine, to an overriding part of the computer  
25 system.

The event processing machine can advantageously be  
adaptive by being arranged to change the internal state  
device and/or the rule base in response to reported event  
reports received by the event processing machine and/or in  
30 response to determined actions. Also the function of the  
filter may be changed in this manner.

The above-mentioned object of the invention is also  
achieved in a method for monitoring and optionally changing  
the operation of a computer system of the type mentioned by  
35 way of introduction, by the steps of incorporating at least  
one event report generator in each program which is execut-  
able in the computer system and whose execution should be

monitored; determining, depending on a rule base which associates a certain event with a predetermined action, the action associated with a reported event; and performing the determined action at least in the form of transmitting a message to a program which is executable in the computer system, for changing or starting thereof.

To avoid overload in the utilisation of the rule base, the above-mentioned actions may suitably be determined merely for some of the reported events which are identical, with the exception of the time of reporting.

The action associated with a certain event can also be made dependent on parameters other than the event's own parameters. These other parameters may suitably be joined in a separate internal state device.

According to the invention, the method can be made adaptive by changing the rule base and/or said other parameters in response to reported events.

For example, the performed actions may also comprise registration of a reported event, and/or forwarding of a reported event to an overriding part of the computer system.

The event report generator which should be included in each program which is executable in the computer system and whose execution should be monitored, consists of program instructions included in the program in suitable positions which normally are determined by the programmer. The events which can be reported may be anything from a normal procedure that has been executed, to a serious error that has occurred. The reported event may for example concern the starting or stopping of something, or the occurrence of an error. This makes it possible to trace the program and see exactly what happens during the execution of the program.

The most interesting events are of course those concerning abnormal or critical situations and errors. Examples of events that could be reported are thus events for program sequencing, events concerning the fact that a certain change has been made in a computer memory, or that

an operator or a program has requested a certain operation, that an error has been detected, that repeated access attempts have been made, and that the storage capacity of a disc is fully utilised. It may also be of interest to report events which may constitute data for statistics, e.g. different users' or different programs' utilisation of various resources in a computer system.

The report of an event must comprise an event identifier which need to be unique in the program concerned only, since before reaching the event processing machine, the event report is automatically supplemented with data regarding its source and the point of time of the generation. In addition to the identifier part, the event report may comprise a computer part containing data which are necessary for making a decision regarding a certain action, or for further processing of the event at issue. The computer part is suitably structured as one or more parameter identifiers and the associated parameter values.

Such programs as should be able to receive an action determined by the event processing machine in the form of a message to the program should of course be provided with program instructions for processing messages received. A determined action may of course consist of a number of subactions comprising a number of messages to different programs in different computers in the computer system. The messages may concern the program execution; for example, in case of a high load on a resource in the computer system, the program may be controlled to use this resource less frequently, or the program may be interrupted. The receipt of a message may in turn trigger an event report, whereby the determining of a certain action may be carried out in response to different events in different programs at different points of time.

The event processing machine, which normally is to be found in a server if there is one local area network, may be realised as software only or as a combination of software and hardware. The rule base in form of software in-

cluded in the event processing machine comprises a set of rules having one condition part and one action part. The condition part preferably comprises a logical combination of a number of subconditions where the information contained in an event report makes it possible to determine whether one or more subconditions are satisfied. The information in the event report, which is useful for this purpose, may consist of information in the event identifier as well as information in the accompanying data, i.e. different parameter values. The satisfying of certain subconditions need, however, not be dependent on the information in a certain event report, but may instead be dependent on internal states in the event processing machine. These internal states are according to the invention represented in the internal state device in which the internal states may concern, for example, the count in different types of counters, the value of a state variable, or the value of a data set.

While taking into consideration that some events may occur at high rate, and that it is not always desirable that each occurrence of the events is received and processed by the event processing machine which then could be overloaded, use is according to the invention suitably made of a filter positioned before the event processing machine and adapted to determine for each separate event whether this should be forwarded to the event processing machine or not. This may be done by forwarding every  $n$ th event of a certain type. The filter is preferably made as software.

The equipment controlled by the event processing machine normally is a combination of software and hardware. The equipment may comprise e.g. memory means for registering the information or parts of the information in an event report. This form of information logging is of great value and allows postprocessing of registered information to produce statistics of various types, for example concerning the performance of the computer system, different users' utilisation of the system, programs in the system or

resources included therein, as well as statistics regarding the occurrence of errors. The equipment also executes actions determined by the event processing machine such as transmitting a message to a program which is executable in the computer system, and starting such a program. Moreover, 5 by means of an action determined by the event processing machine, the equipment can update the state device, change the rule base and also change the function of the filter. The equipment controlled by the event processing machine 10 can also initiate an alarm and forward information, which is essential for the operation of the entire computer system, to an overriding part of the computer system.

An embodiment of the invention will now be described in more detail below with reference to the accompanying 15 drawings. Fig. 1 is a schematic view of a conventional computer system. Fig. 2 is a schematic view illustrating the function of a system according to the present invention. Fig. 3 illustrates in a simplified manner the contents of an object processed by the system according to the inven- 20 tion. Fig. 4 is a schematic view of the configuration of a system according to the invention.

The system according to the invention is preferably used in computer systems which may comprise a number of local area networks LAN1---LANn, as shown in Fig. 1, each 25 local area network comprising a plurality of computers, a server and further equipment, e.g. printers, and the local area networks are being connected with each other and with an overriding part, in the form of e.g. a central server which preferably is physically included in one or some of 30 the local area networks.

As shown in Fig. 2, the event processing according to the invention consists of three phases, viz. a configura- tion phase 1, a running time processing phase 2, and a postprocessing phase 3.

35 The configuration phase 1 comprises registration of processed objects, i.e. programs or certain equipment for the running of programs, events, to be registered, and, for



these events, identifiers and attributes including parameters, as well as configuration of filters, rules and actions.

The running time processing phase 2 includes the  
5 actual processing of reported events on the basis of the previously executed configuration.

The third phase 3 implies postprocessing of the data which according to one type of action have been stored in a log file. Such postprocessing may for example concern the  
10 producing of statistics based on the information logged.

As indicated in Fig. 2, a program developer or administrator is required for the first phase 1, i.e. the configuration phase.

During the running time processing, an event is re-  
15 ported from a processed object 4 and triggers different types of actions, e.g. starting a program 5, transmitting a message to a processed object 6, transmitting a message to a user 7, or logging information in a log file 8 for subsequent postprocessing which can be performed by an ad-  
20 ministrator.

To be processable by means of the system according to the invention for monitoring and, optionally, changing the operation of a computer system, a processed object 4, i.e. normally a program executable in the system, should include  
25 at least one event report generator 9 which reports the occurrence of an event to the event processing system according to the invention (see Fig. 3). Some of the processed objects 4 should also have message receivers 10, i.e. predetermined instructions in an executable program, for  
30 receiving messages from the event processing system according to the invention.

The embodiment of the system according to the invention as illustrated in Fig. 4 concerns a local area network for which one server and only one computer are shown. The  
35 system comprises a server part 11 and a computer part 12. A program executable in the computer part 12, which constitutes a processed object 4, is adapted to report, by means

of its event report generator 9, an event via an interface 13 to a filter 14. The filter 14 is arranged to restrict the number of the reported events which are forwarded to an event processing machine 15 positioned in the server part

5 11. The event processing machine 15 comprises a rule base 16 and an internal state device 17. The event processing machine 15 processes reported events on the basis of the information included in the event report, the rule base 16 and, optionally, the instantaneous state of the state

10 device 17 for determining different types of actions. These may comprise logging information in a log file 18, updating the event processing machine 15, i.e. its rule base 16 and/or its state device 17, changing the filter 14, transmitting a message to a processed object 4 or a user 19, or

15 starting a program 20.

A processed object, such as the object 4, utilises the interface 13 for reporting events to the event processing machine 15 via the filter 14. Via the interface 13, the processed object 14 also receives messages from the event

20 processing machine 15. When an event is reported via the interface 13 to the filter 14, it may either be disregarded, i.e. rejected, or forwarded to the event processing machine 15. This is determined by the filter 14 which is positioned immediately after the interface 13. Each event

25 has its own appearance of the filter which is relatively simple and may be set to disregard a reported event, to forward all events of a certain type to the event processing machine, or to forward every nth event of a certain type to the event processing machine 15.

30 By this construction of the filter 14, the load of the event processing machine 15 will be reduced as will also the load of the network, such that the software itself, i.e. the processed object 4, will not be executed slowly owing to its transmitting event reports.

35 The event processing machine 15 is run in the server 11. Each event reported to the event processing machine from a processed object, i.e. such events as have been

allowed to pass through the filter 14, is processed by the event processing machine 15 in conformity with the configuration thereof. This means that rules in a rule base will be applied to the event. Depending on the rules, the event  
5 can be logged, i.e. information in the event report may be registered, rejected, or some other predetermined action can be performed.

The rules in the event processing machine 15 which are collected in the rule base 16 have the following form:

10       if < condition > then < action >

The condition part may contain tests on the reporting computer, reporting programs, an event, the value of a certain counter, a state, the value of a variable etc. The condition part thus normally constitutes a logical combination  
15 of a number of subconditions, the satisfying of the individual subconditions being dependent on information in the event report and/or in the state device 17.

What is going to occur is described in the action part of the rule, if the condition is satisfied. For example,  
20 the action part may imply one or some of the following requests: logging the event and these parameters to a log file, transmitting a message (e.g. an alarm) to a user, sending a message to a program (processed object), starting a program, updating an internal counter, state variable or  
25 variable, changing a filter value for a certain event for a processed object, forwarding the event report to a higher level in the computer system.

It will be appreciated that in configuring the actual rule base, this will consist of a set of rules, the  
30 number of which will be very large. Since, for each event report received, the event processing machine 15 is essentially forced to go through every rule in the rule base 16 to determine whether a rule therein has been satisfied or not, and thus determine whether a certain action should be  
35 taken, obviously some sort of optimisation of the rule base is desirable. Such an optimisation may be achieved e.g. by analysing the rules of the rule base for determining such

10

conditions, e.g. mutual subconditions in different rules, which allow the rules to be simplified and the number thereof to be reduced. A speeding-up of the event processing machine 15 operating with the rule base 16 can also be  
5 achieved by dividing the rules into a number of levels, i.e. only such events as satisfy a condition on a lower level will be tried against conditions on higher levels.

As is evident from what has been said above, the method and the system according to the invention for monitoring and, optionally, changing the operation of a computer system is an extremely powerful instrument. However, the invention is not limited to the embodiments described above, but a person skilled in the art will be able to  
10 modify the invention within the scope of the appended claims. For example, the event processing machine may be distributed such that it, or parts thereof, may be run in a server in an optional local area network, or even one or  
15 more of the computers included in the system.

20

25

30

35

## CLAIMS

1. System for monitoring and changing the operation of  
5 a computer system which comprises a plurality of computers  
in a local area network or a plurality of interconnected  
local area networks, each having a plurality of computers,  
c h a r a c t e r i s e d b y

at least one event report generator (9) in each prog-  
10 ram (4) which is executable in the computer system and  
whose execution should be monitored;

an event processing machine (15) for processing events  
which are reported by an event report generator in a moni-  
tored program during the execution thereof, depending on a  
15 rule base (16) which is included in the event processing  
machine and associates a certain event with a predetermined  
action, for determining the action associated with the  
reported event;

equipment (18) controlled by the event processing  
20 machine and adapted to perform an action determined by the  
event processing machine; and

an interface (13) for transferring information about  
an event reported by an event report generator in a moni-  
tored program, to an event processing machine, and for  
25 transmitting a message regarding an action associated with  
the event, from the event processing machine, optionally  
via and for processing in a further event processing  
machine, to a program executable in said computer system,  
for changing or starting thereof.

30 2. System as claimed in claim 1, c h a r a c t e r -  
i s e d b y a filter (14) directly connected to said inter-  
face (13) and adapted to restrict the number of the events  
reported which are forwarded to the event processing ma-  
chine (15).

35 3. System as claimed in claim 1 or 2, c h a r a c -  
t e r i s e d in that said event processing machine (15)  
comprises an internal state device (17), and that said rule

base (16) is adapted to associate a certain event with a predetermined action which depends on the instantaneous state of the internal state device.

4. System as claimed in any one of claims 1-3,  
5 c h a r a c t e r i s e d in that the equipment controlled by said event processing machine (15) also comprises means for registration (18) of a reported event and/or for forwarding a reported event to an overriding part of the computer system.

10 5. System as claimed in any one of claims 1-4, c h a r a c t e r i s e d in that said event processing machine (15) is adapted to change the internal state device (17) and/or the rule base (16) and/or the filter (14) in response to reported events received by said event processing machine and/or in response to determined actions.

15 6. Method for monitoring and changing the operation of a computer system which comprises a plurality of computers in a local area network or a plurality of interconnected local area networks, each having a plurality of computers,  
20 c h a r a c t e r i s e d by the steps of

incorporating at least one event report generator in each program which is executable in the computer system and whose execution should be monitored;

25 determining, depending on a rule base which associates a certain event with a predetermined action, the action associated with a reported event; and

performing the determined action at least in the form of transmitting a message to a program which is executable in the computer system, for changing or starting thereof.

30 7. Method as claimed in claim 6, c h a r a c t e r i s e d in that said action is determined merely for some of the reported events which are identical, with the exception of the time of reporting.

35 8. Method as claimed in claim 6 or 7, c h a r a c t e r i s e d in that the action associated with a certain event is also made dependent on parameters other than the event's own parameters.

13

9. Method as claimed in any one of claims 6-8,  
c h a r a c t e r i s e d in that the actions performed  
also comprise registration of a reported event and/or for-  
warding of a reported event to an overriding part of the  
5 computer system.

10. Method as claimed in claim 8 or 9, c h a r a c -  
t e r i s e d in that the rule base and/or said other  
parameters are caused to change in response to reported  
events.

10

15

20

25

30

35

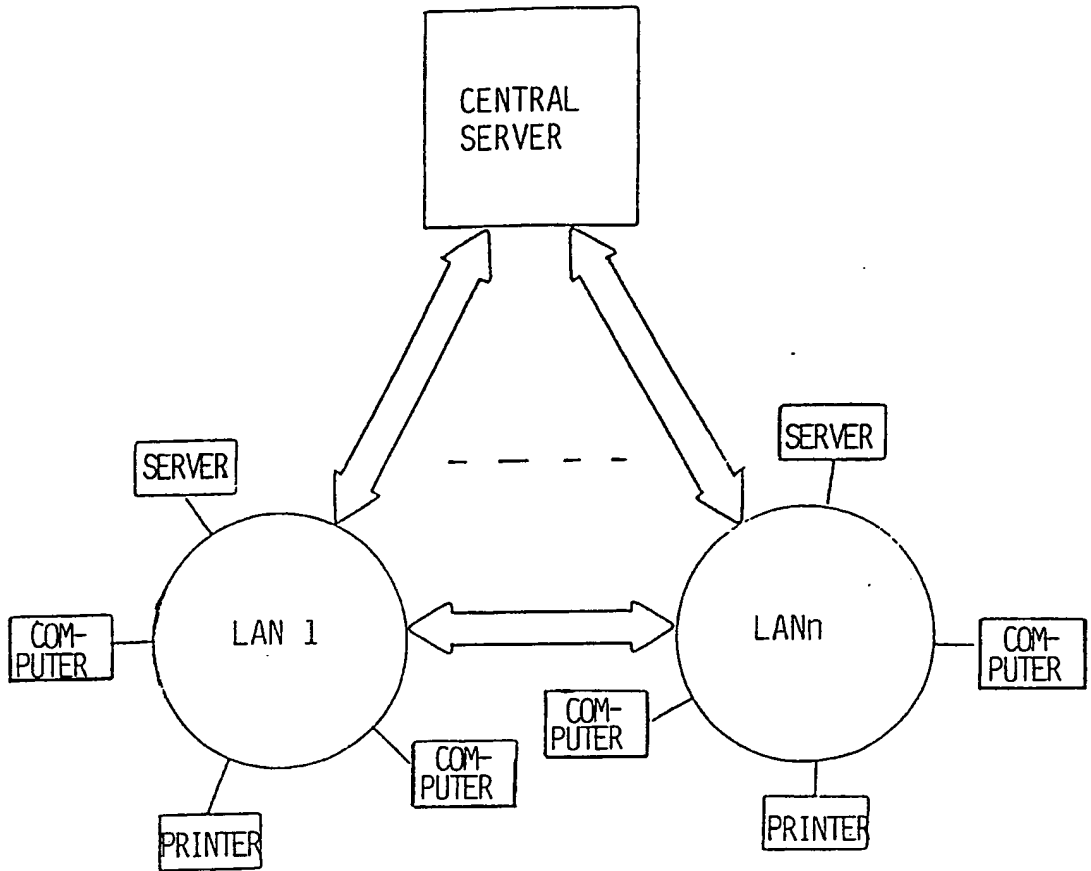

FIG 1

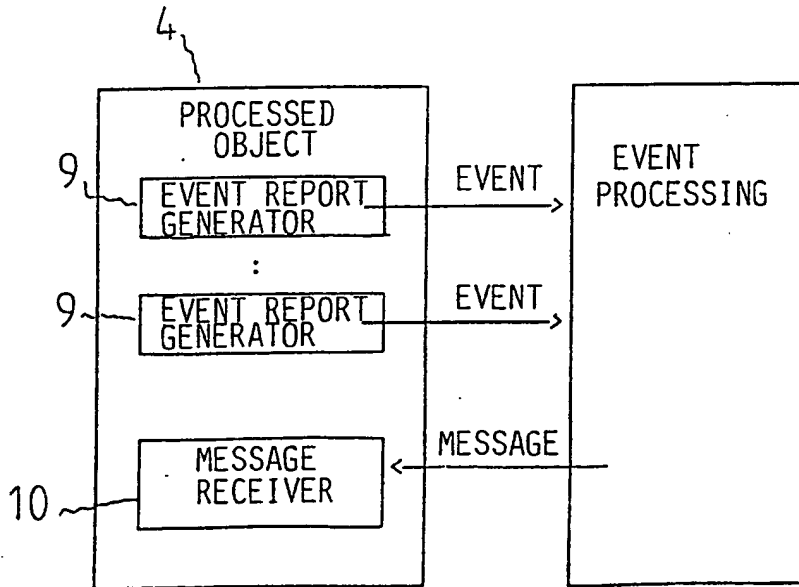

FIG 3



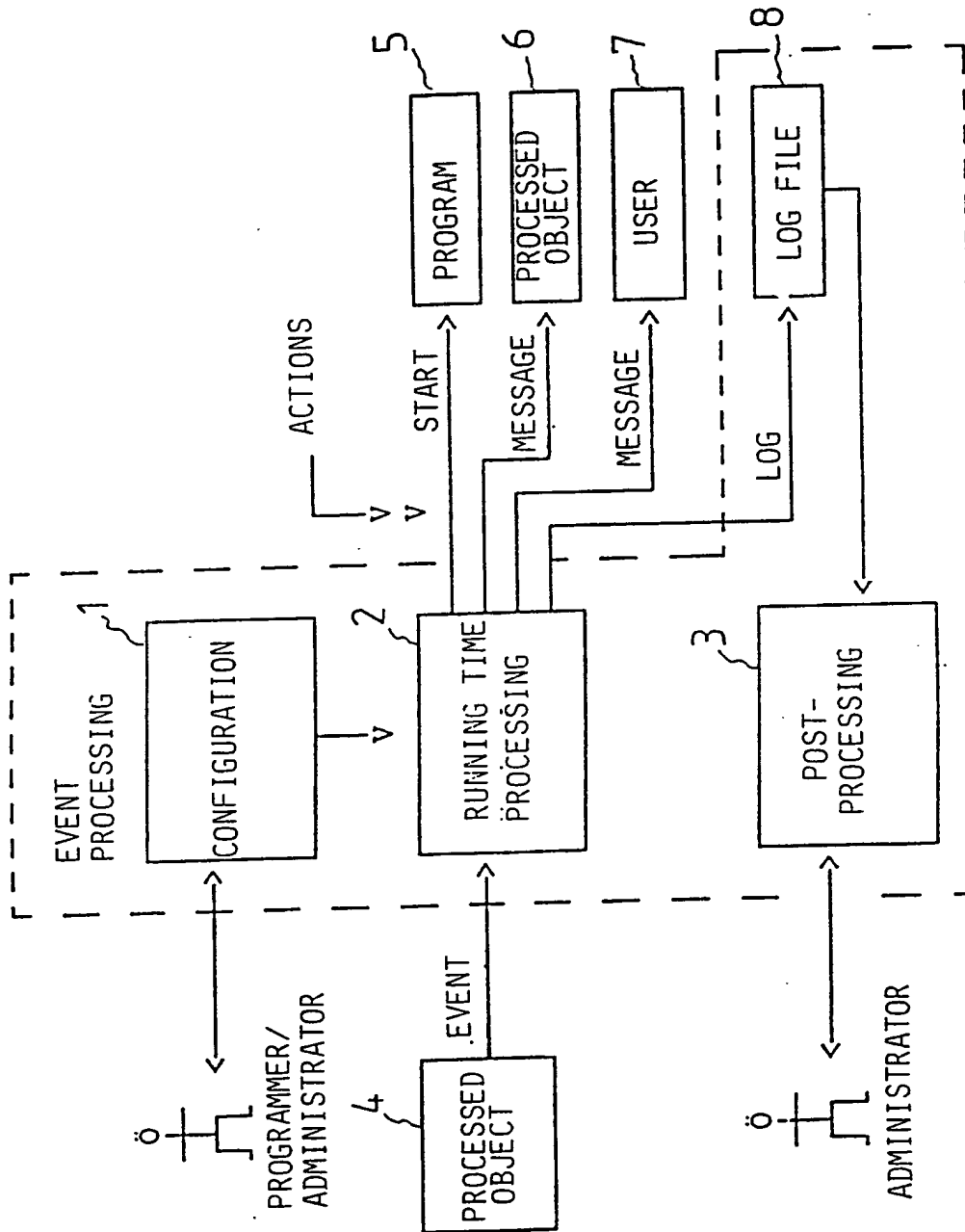

FIG 2

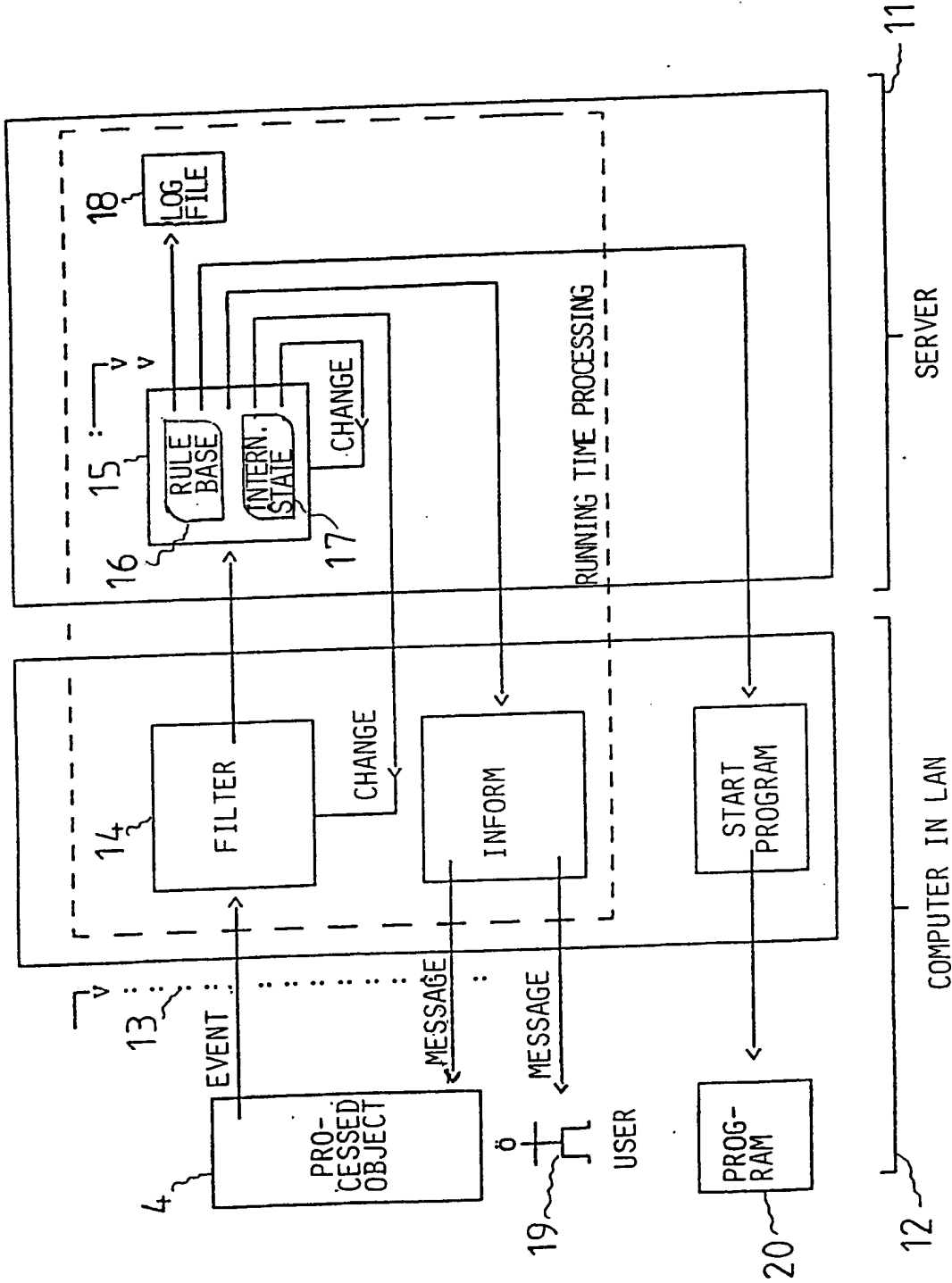



FIG 4

# INTERNATIONAL SEARCH REPORT

International Application No **PCT/SE 92/00456**

<b>I. CLASSIFICATION OF SUBJECT MATTER</b> (if several classification symbols apply, indicate all) <sup>6</sup>		
According to International Patent Classification (IPC) or to both National Classification and IPC		
IPC5: G 06 F 11/34		
<b>II. FIELDS SEARCHED</b>		
Minimum Documentation Searched <sup>7</sup>		
Classification System	Classification Symbols	
IPC5	G 06 F	
Documentation Searched other than Minimum Documentation to the Extent that such Documents are Included in Fields Searched <sup>8</sup>		
SE,DK,FI,NO classes as above		
<b>III. DOCUMENTS CONSIDERED TO BE RELEVANT<sup>9</sup></b>		
Category *	Citation of Document, <sup>11</sup> with indication, where appropriate, of the relevant passages <sup>12</sup>	Relevant to Claim No. <sup>13</sup>
Y	US, A, 3575589 (FARID J. NEEMA ET AL) 20 April 1971, see column 2, line 23 - line 58; column 9, line 4 - line 13; figure 1 --	1-4,6-9
Y	Patent Abstracts of Japan, Vol 12, No 280, P739, abstract of JP 63- 59638, publ 1988-03-15 MITSUBISHI ELECTRIC CORP. --	1-4,6-9
Y	EP, A2, 0257241 (INTERNATIONAL BUSINESS MACHINES) 2 March 1988, see column 16, line 9 - column 17, line 20; figure 2 --	2,7
Y	US, A, 3906454 (ROBERT LANHAM MARTIN) 16 September 1975, see column 3, line 40 - column 5, line 42; figure 1 --	2,3,7,8
<p>* Special categories of cited documents:<sup>10</sup></p> <p>"A" document defining the general state of the art which is not considered to be of particular relevance</p> <p>"E" earlier document but published on or after the international filing date</p> <p>"L" document which may throw doubts on priority claim(s) or which is cited to establish the publication date of another citation or other special reason (as specified)</p> <p>"O" document referring to an oral disclosure, use, exhibition or other means</p> <p>"P" document published prior to the international filing date but later than the priority date claimed</p> <p>"T" later document published after the international filing date or priority date and not in conflict with the application but cited to understand the principle or theory underlying the invention</p> <p>"X" document of particular relevance, the claimed invention cannot be considered novel or cannot be considered to involve an inventive step</p> <p>"Y" document of particular relevance, the claimed invention cannot be considered to involve an inventive step when the document is combined with one or more other such documents, such combination being obvious to a person skilled in the art.</p> <p>"&amp;" document member of the same patent family</p>		
<b>IV. CERTIFICATION</b>		
Date of the Actual Completion of the International Search	Date of Mailing of this International Search Report	
15th September 1992	23 -09- 1992	
International Searching Authority	Signature of Authorized Officer	
<b>SWEDISH PATENT OFFICE</b>	 <b>KATARINA FREDRIKSSON</b>	

III. DOCUMENTS CONSIDERED TO BE RELEVANT (CONTINUED FROM THE SECOND SHEET)		
Category *	Citation of Document, with indication, where appropriate, of the relevant passages	Relevant to Claim No
A	<p>Patent Abstracts of Japan, Vol 12, No 470, P798,                      abstract of JP 63-189949, publ 1988-08-05                      NEC CORP.</p> <p style="text-align: center;">--                      -----</p>	1-10

**ANNEX TO THE INTERNATIONAL SEARCH REPORT  
ON INTERNATIONAL PATENT APPLICATION NO. PCT/SE 92/00456**

This annex lists the patent family members relating to the patent documents cited in the above-mentioned international search report. The members are as contained in the Swedish Patent Office EDP file on **28/08/92**. The Swedish Patent Office is in no way liable for these particulars which are merely given for the purpose of information.

Patent document cited in search report	Publication date	Patent family member(s)	Publication date
US-A- 3575589	71-04-20	NONE	
EP-A2- 0257241	88-03-02	JP-A- 63047852 US-A- 4821178	88-02-29 89-04-11
US-A- 3906454	75-09-16	CA-A- 1017066 DE-A- 2423719 FR-A-B- 2230017 GB-A- 1474235 JP-A- 50020634	77-09-06 74-12-12 74-12-13 77-05-18 75-03-05

**This Page is Inserted by IFW Indexing and Scanning  
Operations and is not part of the Official Record**

**BEST AVAILABLE IMAGES**

Defective images within this document are accurate representations of the original documents submitted by the applicant.

Defects in the images include but are not limited to the items checked:

- BLACK BORDERS**
- IMAGE CUT OFF AT TOP, BOTTOM OR SIDES**
- FADED TEXT OR DRAWING**
- BLURRED OR ILLEGIBLE TEXT OR DRAWING**
- SKEWED/SLANTED IMAGES**
- COLOR OR BLACK AND WHITE PHOTOGRAPHS**
- GRAY SCALE DOCUMENTS**
- LINES OR MARKS ON ORIGINAL DOCUMENT**
- REFERENCE(S) OR EXHIBIT(S) SUBMITTED ARE POOR QUALITY**
- OTHER:** \_\_\_\_\_

**IMAGES ARE BEST AVAILABLE COPY.**

**As rescanning these documents will not correct the image problems checked, please do not report these problems to the IFW Image Problem Mailbox.**